

KOMATSU

DX20 series

7.0 to 8.0 ton Diesel and Gasoline Engine Lift Trucks



EPA Tier 2/EU stage II Emission compliant

KOMATSU FORKLIFT

The perfect machine for



The lift truck in this photograph is equipped with optional accessories.

the job

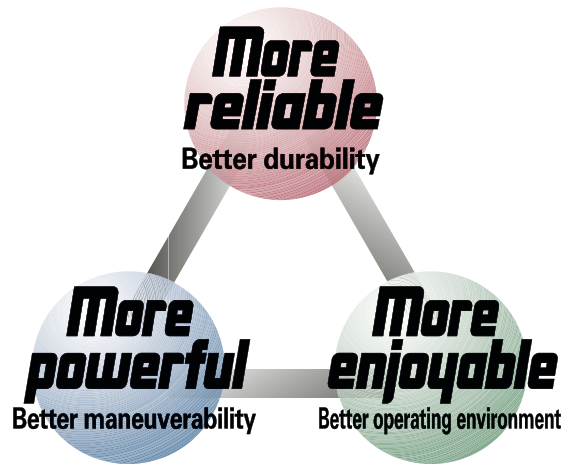

DX20 SERIES

Our goal is to build forklifts that are ideally suited to your needs. Machines with improved durability. Heavy-duty machines that are designed to strict specifications and that have all the functions you would expect, and then some.

We designed the DX20 series to meet stringent requirements for rigorous professional use. This guarantees more efficient operation, even on demanding job sites.



The LPG-powered FG70-7,
with 4.0 m FV mast and side shifter

More reliable

Better durability

The Most Rigid Mast Frame in its Class



Mast

We've increased the cross-sectional area of the mast rails, used high-strength steel and strengthened the tilt cylinder connections. These improvements substantially raise the rigidity of the mast rails.

Front axle

We used a single, thick plate for the connection between the front axle and the frame, and increased the thickness of the lateral plates, significantly boosting overall rigidity.

Front fenders

To improve rigidity, the front fenders are made of a single, thick layer.

A Reliable Hydraulic System—even under Extreme Conditions

High-capacity twin-cooler system

The system adopts an air-cooled oil cooler and a water-cooled torque converter cooler. Both coolers have high coolant capacities. This means they can perform reliably, keeping hydraulic temperatures low even under severe operating conditions. The result is a reliable, long-life hydraulic system. (7.0ton type employs a water- & air-cooled torque converter.)



Tandem flow divider with combined flow regeneration circuit (diesel model)

The DX20 series uses a hydraulic regeneration circuit with a tandem pump to minimize the rise in hydraulic oil temperature, even under demanding operating conditions. The cast-metal pump that is used on (8.0 ton) trucks is particularly effective at cooling.



Maintaining oil purity

The spin-on hydraulic oil filter prevents dirt from entering the hydraulic system. This improves system reliability and makes maintenance easier. Also, a transmission line filter prevents trouble in the machine's drive train.



Protected brake piping

For protection, brake piping is routed inside the lower frame members.

Alternator with internal IC regulator

An IC maintains steady regulator voltage, so that a stable voltage is supplied throughout the truck. The IC also protects the circuit from damage caused by current surges.



Protected tilt cylinder piping

Tilt cylinder piping is located inside the dashboard, protecting it from damage in the event of a collision or a dropped load.



Standard sedimenter (diesel model)

By separating out water from the fuel, the sedimenter raises injection pump reliability. (7.0ton)



Careful Design Extending to Chassis Details

Integrated bonnet

Making the bonnet an integrated unit has improved its durability. Also, the rounded contours of the upper surface shed water, keeping the bonnet free of rust.



Standard halogen lamps

For maximum illumination, bright white long-life halogen lamps are standard on the DX20 series. Guards protect the lamp from damage.



Rear axle

By strengthening each area, we've improved the rigidity of the entire axle.



***A rigid structure—
The first evidence of a reliable machine***

The lift truck in this photograph is equipped with optional accessories.

More powerful

Better maneuverability

*Power-based performance—
You can feel the difference*

Powerful and Clean



Rated output

77 kW
@2250rpm

Piston displacement: **5880cm³**

S6D102E

The highest displacement

—FD70

Because of the highest displacement in its class together with a turbo charger, these engines provide overwhelming power and superb driving performance. The engine's reentrant-type fuel chamber guarantees an ideal combustion performance that conforms the second stage regulations for emission gases in North America and Europe. This engine is friendly both to people and the environment.

SA6D102E Increased power with an after-cooler —FD80 Diesel engine

The S6D102E engine is equipped with a water-cooled after-cooler. This boosted engine torque enables a more powerful drive over an entire range of operations enabling quick and light operations of high-loaded jobs. The end result is increased work efficiency. This engine is compliant with EPA Tier 2/EU Stage II Emissions regulations and realizes both high power and clean emissions.

Rated output
96kW@2250rpm

Piston displacement
5880cm³

TB45E Powerful, yet silent —FG70 Gasoline engine

In addition to power and excellent fuel efficiency, the crankshaft has an eight-counterweight balance to minimize engine noise and vibration. The radiator fan is made of plastic to improve the engine's heat balance and reduce noise. The engine is also fitted with a vacuum pump to produce vacuum pressure for the brakes.

Rated output
70kW@2400rpm

Piston displacement
4478cm³

Superior Loading and Unloading for Higher Operating Efficiency

High-speed fork lifting and lowering

High torque guarantees that the engine is ideally suited for forklift operation. The use of a combined flow regeneration circuit with tandem flow divider and a cast tandem pump maximizes lifting speed.

Lifting speed (unloaded)
500 mm/s
7.0/8.0 ton diesel models

Lowering speed (unloaded)
500 mm/s
7.0 ton diesel model

Improved Travel and Braking Performance

Top travel speed and gradeability

These characteristics maximize efficiency on a variety of sites.

Maximum travel speed (unloaded)

32.0 km/h
7.0 ton diesel model

Maximum gradeability (loaded)

29.8%
7.0 ton diesel model

Smooth initial acceleration

The transmission is equipped with a modulator valve, as well as an electrical two-speed valve and a conical plate to ensure smooth, yet

Acceleration from 0~20m (unloaded)

6.2 sec.
7.0 ton model

Optional setting for automatically shifting two-speed torque converter (optional)

An optional setting allows the automatic transmission to perform the shift from first to second gear automatically. This allows the operator to concentrate on efficiently performing the work at hand, instead of on changing gears.

HydroMaster brakes for reliable braking power (7.0ton)

The braking system uses a vacuum-based HydroMaster system as a brake assist unit. Vacuum pressure assists power cylinder operation, and the wheel cylinders operate due to power cylinder pressure, resulting in excellent braking performance. Even if the engine stalls, fluid flows from the vacuum tank to the assist mechanism to guarantee reliable braking power. The eight-ton type employs a full hydraulic power brake.

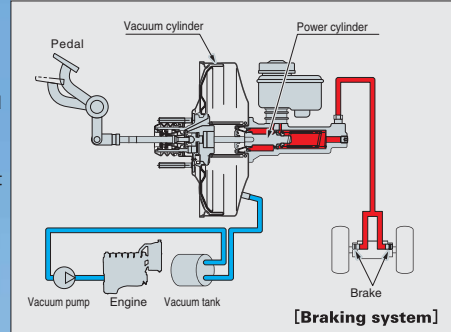

Swift footwork

DX20 series machines have small turning radii and nimble steering, so changes in direction are almost instantaneous. This contributes to rapid cycle times.

3350 mm

Minimum turning radius

Outside radius for 7.0 ton model



The lift truck in this photograph is equipped with optional accessories.

More enjoyable

Better operating environment



Large, easy-to-reach assist grips

Rounded pedal area

Wide, slip-resistant step

Flat floor that is easy on the feet

Excellent Front and Rear Visibility



Superb forward visibility

Eliminating the intermediate inner mast stay improves visibility when loading the truck. The masts are colored an unobtrusive gray, while the forks are painted an easy-to-see yellow.

Outstanding fork tip visibility

Using a compact meter panel, selecting an appropriate mounting location and using a two-spoke steering wheel improve the operator's visibility of the fork tips.



Easy Maintenance

Handle for opening the bonnet

You can open the bonnet without having to tilt back the steering wheel, as the steering wheel automatically retracts.

Angled bonnet sides

The sides of the bonnet are angled to make inspections easier. The bonnet is a single unit, beginning at the point where it hinges away from the floor plate. This avoids the need to remove the floor plate before servicing.

Reliable, Light-Touch Operating System

Electrically controlled forward-reverse lever operates at the touch of a finger

The shifting force has been reduced by 60%, so the operator can shift from first to second gear without removing his hands from the steering wheel. This minimizes fatigue even after hours on the job.

60%

Reduction in force required to shift gears (compared with previous Komatsu models)

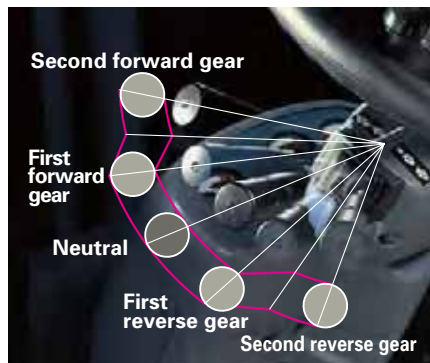

Combination switch for head lamp and directional indicator (Auto-return)

As in an automobile, switches for the lights and turn signals are all on the same lever. The turn signals cancel automatically, so the operator need not remember to manually cancel the signal.



Integrated meter panel for single-view checking



Meters

- 1 Hourmeter
- 2 Water temperature gauge
- 3 Torque converter oil temperature gauge
- 4 Needle-type fuel gauge

Safety indicators

- 5 Brake oil level warning lamp
- 6 Engine oil pressure warning lamp
- 7 Charge warning lamp
- 8 Operation lamp
- 9 Air cleaner element warning lamp
- 10 Coolant level warning lamp
- 11 Sediment warning lamp (diesel model)
- 12 Parking brake lamp

Excellent operator-machine interface— Maximizing operator comfort

Low Noise and Vibration for a Comfortable Operating Environment

Hydraulic Suspension Cab (HSC) for a soft ride

The HSC system isolates the entire cabin space from the chassis, greatly reducing operating vibrations. This system is particularly effective when used with Komatsu's unique, non-puncture tires, which offer little vibration damping.



Extremely quiet

The combination of an integrated bonnet, a low-noise engine and various other noise-suppressing equipment succeeds in greatly reducing the noise that reaches the operator's ears.

Diesel model (7.0ton)

69 dB(A)

reaches the operator's ears (during low idle)



Adjustable deluxe operator seat

With adjustment functions for reclining, front-rear slide and suspension, this seamless blow-formed seat offers excellent comfort, as well as durability. Other features include a retracting seat belt and a rear



Thoughtful design



Memo binder

The lift truck in this photograph is equipped with optional accessories.

Designed to simplify maintenance

The floor plate and radiator cover can be removed at a single touch. (7.0ton)



Easily removable floor plate



Removable radiator cover

Ensuring a High Level of Safety

Bonnet lock and stopper

The bonnet lock prevents the bonnet from lifting up when the truck runs over bumps in the floor. The bonnet stopper keeps strong winds from closing the bonnet accidentally.



Bonnet lock

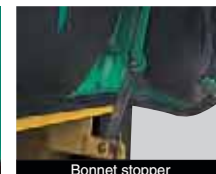

Bonnet stopper

Specifications

| | | | | | |
|-------------------|--------------|----------------------------------|---|-------------------------------------|---------|
| Characteristics | 1.2 | Model | Manufacturer's Designation | | |
| | 1.3 | Power Type | Electric, Diesel, Gasoline, LPG, Cable | | |
| | 1.4 | Operator Type | Pedestrian, Driver Standing, Sitting, Order Picking | | |
| | 1.5 | Rated Capacity | Q | Capacity at 600mm (24") Load Center | |
| | 1.8 | Load Distance | x | From Center of Front Axle | |
| Weights | 1.9 | Wheelbase | y | mm (in) | |
| | 2.1 | Service Weight | | kg (lb) | |
| | 2.2 | Axle Loading | Loaded | Front | kg (lb) |
| | | | | Rear | kg (lb) |
| | 2.3 | | Unloaded | Front | kg (lb) |
| Rear | | | | kg (lb) | |
| Tire | 3.1 | Tire Type | Solid, Pneumatic | | |
| | 3.2 | Tire Size | Front | | |
| | 3.3 | | Rear | | |
| | 3.5 | Number of Wheel | Front/Rear(x=driven) | | |
| | 3.6 | Tread, Front | b ₁₀ | mm (in) | |
| Basic Measurement | 3.7 | Tread, Rear | b ₁₁ | mm (in) | |
| | 4.1 | Tilting Angle | α/β | Forward/Backward degree | |
| | 4.2 | Mast Height, Lowered | h ₁ | With Std. Mast mm (in) | |
| | 4.3 | Std. Free Lift | h ₂ | With Std. Mast from Ground mm (in) | |
| | 4.4 | Std. Lift Height | h ₃ | With Std. Mast from Ground mm (in) | |
| | 4.5 | Mast Height, Extended | h ₄ | With Std. Mast mm (in) | |
| | 4.7 | Height, Overhead Guard | h ₆ | mm (in) | |
| | 4.20 | Length, to Face Forks | l | mm (in) | |
| | 4.21 | Width, at Tire | b ₁ | mm (in) | |
| | 4.22 | Forks | s/e// | Thickness x Width x Length mm (in) | |
| | 4.24 | Width, Fork Carriage | b ₃ | Max./Min. mm (in) | |
| | 4.31 | Ground Clearance | m ₁ | Under the Mast mm (in) | |
| | 4.32 | | m ₂ | at the Center of Wheelbase mm (in) | |
| | 4.33 | Right Angle Stacking Aisle | Ast | mm (in) | |
| | 4.35 | Turning Radius | Wa | mm (in) | |
| Performance | 5.1 | Travel Speed (FWD) | Loaded, 1st/2nd | km/h (mph) | |
| | 5.1.1 | | Unloaded, 1st/2nd | km/h (mph) | |
| | 5.2 | Lifting Speed | Loaded/Unloaded | mm/s (fpm) | |
| | 5.3 | Lowering Speed | Loaded/Unloaded | mm/s (fpm) | |
| | 5.6 | Max. Drawbar Pull | 1.5km/h, 3min rating | Loaded | kN (lb) |
| | 5.8 | Max. Grade ability | 1.5km/h, 3min rating | Loaded | % |
| | 5.10 | Service Brake | | | |
| | 5.11 | Parking Brake | | | |
| Drive | 6.4 | Battery | Voltage/Capacity 5-Hour Rating V/Ah | | |
| | 7.1 | Make/Model | | | |
| | 7.2 | Rated Output/Speed, SAE gross | | kW (HP) @ rpm | |
| | 7.3 | Max. Torque/Speed, SAE gross | | N.m (lb.ft) @ rpm | |
| Others | 7.4 | Number of Cylinders/Displacement | | cm ³ (cu.in) | |
| | 7.6 | Fuel Tank Capacity | | Ltr (U.S.gal) | |
| | 8.2 | Relief Pressure for Attachment | | bar (psi) | |
| | 8.2.1 | Hydraulic Tank Capacity | | Ltr (U.S.gal) | |
| | 8.6 | Clutch | | | |
| 8.7 | Transmission | | | | |

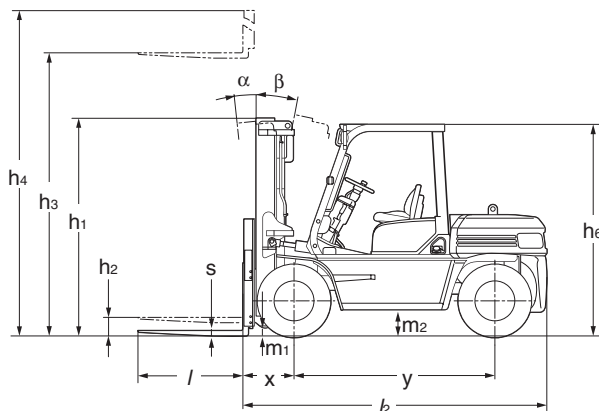
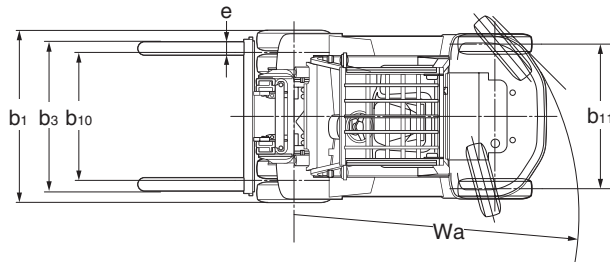

STANDARD EQUIPMENT

- Headlights
- Turn signals
- Stop and tail lights
- Back up light
- Engine key stop (Diesel)
- Horn
- Torque converter oil cooler
- Power brake
- Cyclonic air cleaner
- Tilttable steering column
- Drawbar pin

Safety indicators

- Engine oil pressure warning lamp
- Charge warning lamp
- Air cleaner element warning lamp
- Parking brake lamp
- Coolant level warning lamp
- Brake oil level warning lamp
- Sedimenter warning lamp(Diesel)
- Operation lamp
- Preheating indicator (Diesel)

Meters

- Water temperature gauge
- Fuel gauge
- Torque converter oil temperature gauge
- Hourmeter

ATTACHMENTS

- Side shifter
- Bale clamp
- Manipulator
- Hinged forks
- Fork positioner
- Side shifting type fork positioner
- Ram

There are more options and attachments. Please contact with your Komatsu dealer for the availability.

| | FD70-8 | | FG70-8 | | FD80-8 | | 1.2 | Characteristics |
|--|------------------------------------|--|------------------------------------|--|------------------------------------|--|-------|-----------------|
| | Diesel | | Gasoline | | Diesel | | | |
| | Sitting | | Sitting | | Sitting | | 1.3 | Weights |
| | 7000 (15,400) | | 7000 (15,400) | | 8000 (18,000) | | 1.4 | |
| | 585 (23.0) | | 585 (23.0) | | 675 (26.6) | | 1.5 | |
| | 2300 (90.5) | | 2300 (90.5) | | 2500 (98.4) | | 1.8 | |
| | 9245 (20,380) | | 9050 (19,950) | | 10995 (24,240) | | 2.1 | |
| | 14330 (31,590) | | 14285 (31,490) | | 17020 (37,520) | | 2.2 | |
| | 1915 (4,220) | | 1765 (3,890) | | 1975 (4,350) | | 2.2.1 | |
| | 3725 (8,210) | | 3680 (8,110) | | 4845 (10,680) | | 2.3 | |
| | 5220 (11,510) | | 5370 (11,840) | | 6150 (13,560) | | 2.3.1 | |
| | Pneumatic | | Pneumatic | | Pneumatic | | 3.1 | Tire |
| | 8.25-15-14PR(I) | | 8.25-15-14PR(I) | | 9.00-20-12PR(I) | | 3.2 | |
| | 8.25-15-14PR(I) | | 8.25-15-14PR(I) | | 9.00-20-12PR(I) | | 3.3 | |
| | 4x/2 | | 4x/2 | | 4x/2 | | 3.5 | |
| | 1450 (57.1) | | 1450 (57.1) | | 1540 (60.6) | | 3.6 | |
| | 1640 (64.6) | | 1640 (64.6) | | 1700 (66.9) | | 3.7 | |
| | 6/12 | | 6/12 | | 6/12 | | 4.1 | |
| | 2585 (101.8) | | 2585 (101.8) | | 2710 (106.7) | | 4.2 | |
| | 220 (8.7) | | 220 (8.7) | | 220 (8.7) | | 4.3 | |
| | 3000 (118) | | 3000 (118) | | 3000 (118) | | 4.4 | |
| | 4350 (171.2) | | 4350 (171.2) | | 4350 (171.2) | | 4.5 | |
| | 2440 (96.1) | | 2440 (96.1) | | 2610 (102.7) | | 4.7 | |
| | 3565 (140.3) | | 3565 (140.3) | | 3875 (152.5) | | 4.20 | |
| | 1960 (77.2) | | 1960 (77.2) | | 2120 (83.5) | | 4.21 | |
| | 65 x 150 x 1220 (2.5 x 5.9 x 48.0) | | 65 x 150 x 1220 (2.5 x 5.9 x 48.0) | | 65 x 170 x 1220 (2.5 x 6.7 x 48.0) | | 4.22 | |
| | 1720/300 (67.7/11.8) | | 1720/300 (67.7/11.8) | | 1829/340 (72/13.4) | | 4.24 | |
| | 225 (8.8) | | 225 (8.8) | | 250 (9.8) | | 4.31 | |
| | 285 (11.2) | | 285 (11.2) | | 335 (13.2) | | 4.32 | |
| | 3935 (154.9) | | 3935 (154.9) | | 4275 (168.3) | | 4.33 | |
| | 3350 (131.9) | | 3350 (131.9) | | 3600 (141.7) | | 4.35 | |
| | 11.0 (6.8)/30.0 (18.6) | | 11.0 (6.8)/28.0 (17.4) | | 12.0 (7.5)/31.0 (19.3) | | 5.1 | |
| | 12.0 (7.5)/32.0 (19.9) | | 12.0 (7.5)/32.0 (19.9) | | 12.5 (7.8)/33.0 (20.5) | | 5.1.1 | |
| | 450/500 (89/98) | | 365/390 (72/77) | | 455/500 (90/98) | | 5.2 | |
| | 550/500 (108/98) | | 550/550 (108/108) | | 500/450 (98/89) | | 5.3 | |
| | 46.1 (10,350) | | 42.1 (9,470) | | 57.6 (12,950) | | 5.6 | |
| | 29.8 | | 24.2 | | 32.7 | | 5.8 | |
| | Hydraulic, Powered | | Hydraulic, Powered | | Hydraulic, Powered | | 5.10 | |
| | Mechanical | | Mechanical | | Mechanical | | 5.11 | |
| | Power Steering | | Power Steering | | Power Steering | | 5.12 | |
| | 24/52 | | 12/48 | | 24/52 | | 6.4 | |
| | KOMATSU S6D102E | | NISSAN TB45E | | KOMATSU SA6D102E | | 7.1 | |
| | 77 (103) @2250 | | 70 (95) @2400 | | 96 (129) @2250 | | 7.2 | |
| | 392 (289) @1000 | | 276 (203) @1600 | | 466 (344) @1600 | | 7.3 | |
| | 6/5880 (359) | | 6/4478 (273) | | 6/5880 (359) | | 7.4 | |
| | 140 (37) | | 140 (37) | | 140 (37) | | 7.6 | |
| | 181 (2,630) | | 181 (2,630) | | 181 (2,630) | | 8.2 | |
| | 70 (18) | | 70 (18) | | 70 (18) | | 8.2.1 | |
| | Torque Converter | | Torque Converter | | Torque Converter | | 8.6 | |
| | TORQFLOW | | TORQFLOW | | TORQFLOW | | 8.7 | |

FD70/FG70

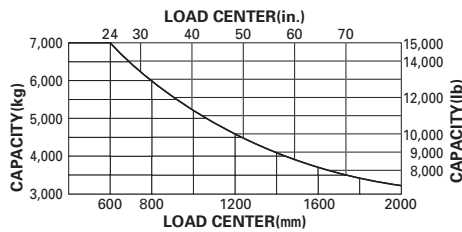

Capacities shown are for trucks equipped with 2-stage view mast up through 5000mm (197in.) maximum fork height, 1700mm(66.9in.) carriage, 1220mm(48in.) forks. Contact your distributor or dealer for capacity information with other equipment.

FD80

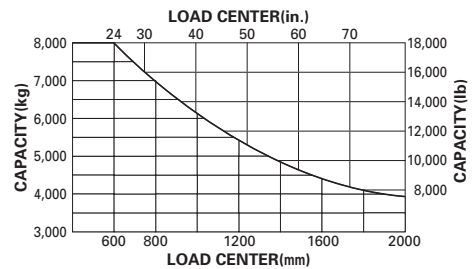

Capacities shown are for trucks equipped with 2-stage view mast up through 5000mm (197in.) maximum fork height, 1800mm(70.9in.) carriage, 1220mm(48in.) forks. Contact your distributor or dealer for capacity information with other equipment.

| Maximum fork height mm(in) | Overall height mm (in) | | Load* capacity kg (lb) | Free lift mm (in) B | Back tilt restriction β |
|--------------------------------|------------------------|-------------|------------------------|---------------------|-------------------------|
| | Lowered J | Extended K | | | |
| 2-stage view mast** | | | | | |
| 3000 (118) | 2585(101.8) | 4350(171.3) | 7000 (15,400) | 220(8.7) | 12° |
| 3500 (138) | 2835(111.6) | 4850(190.9) | | | |
| 4000 (157) | 3085(121.4) | 5350(210.6) | | | |
| 4500 (177) | 3435(135.2) | 5850(230.3) | | | |
| 5000 (197) | 3785(149.0) | 6350(250.0) | | | |
| 5500 (217) | 4135(162.8) | 6850(269.7) | | | |
| 6000 (236) | 4385(172.6) | 7350(289.4) | 6700(14,770) | 6500(14,330) | |
| 2-stage full free view mast*** | | | | | |
| 3000 (118) | 2585(101.8) | 4210(165.7) | 6600(14,550) | 1455(57.3) | 10° |
| 3300 (130) | 2735(107.7) | 4510(177.6) | | | |
| 3500 (138) | 2835(111.6) | 4710(185.4) | | | |
| 4000 (157) | 3085(121.5) | 5210(205.1) | | | |
| 3-stage full free view mast*** | | | | | |
| 4000 (157) | 2400 (94.5) | 5105(201.0) | 6400(14,110) | 1405(55.3) | 6° |
| 4300 (169) | 2500 (98.4) | 5405(212.8) | | | |
| 4500 (177) | 2550(100.4) | 5600(220.5) | | | |
| 5000 (197) | 2750(108.3) | 6100(240.2) | | | |
| 5500 (217) | 2950(116.1) | 6600(259.8) | | | |
| 6000 (236) | 3150(124.0) | 7100(279.5) | | | |
| | | | 6300(13,890) | 6100(13,450) | 1960(77.2) |
| | | | 5500(12,130) | 2160(85.0) | |

Standard mast is shown in broad frame.
 * Load capacity at 600mm (24in.) load center.
 ** 1280mm (50.4 in.) height load backrest.
 *** Free lift and Overall height (Extended) shown are for truck without load backrest.

| Maximum fork height mm(in) | Overall height mm (in) | | Load* capacity kg (lb) | Free lift mm (in) B | Back tilt restriction β |
|--------------------------------|------------------------|-------------|------------------------|---------------------|-------------------------|
| | Lowered J | Extended K | | | |
| 2-stage view mast** | | | | | |
| 3000 (118) | 2710(106.7) | 4350(171.3) | 8000 (17,640) | 220(8.7) | 12° |
| 3500 (138) | 2960(116.5) | 4850(190.9) | | | |
| 4000 (157) | 3210(126.4) | 5350(210.6) | | | |
| 4500 (177) | 3560(140.2) | 5850(230.3) | | | |
| 5000 (197) | 3910(153.9) | 6350(250.0) | | | |
| 5500 (217) | 4260(167.7) | 6850(269.7) | | | |
| 6000 (236) | 4510(177.6) | 7350(289.4) | 7700(16,980) | 7500(16,530) | |
| 2-stage full free view mast*** | | | | | |
| 3000 (118) | 2705(106.5) | 4180(164.6) | 7900(17,420) | 1605(63.1) | 10° |
| 3300 (130) | 2855(112.4) | 4480(176.4) | | | |
| 3500 (138) | 2955(116.3) | 4680(184.3) | | | |
| 4000 (157) | 3205(126.2) | 5180(203.9) | | | |
| 3-stage full free view mast*** | | | | | |
| 4000 (157) | 2605 (102.6) | 5315(209.3) | 7200(15,870) | 1400(55.1) | 6° |
| 4300 (169) | 2705 (106.5) | 5615(221.1) | | | |
| 4500 (177) | 2755(108.5) | 5815(228.9) | | | |
| 5000 (197) | 2955(116.3) | 6315(248.6) | | | |
| 5500 (217) | 3155(124.2) | 6815(268.3) | | | |
| 6000 (236) | 3355(132.1) | 7315(288.0) | | | |
| | | | 7000(15,400) | 6500(14,330) | 1950(76.8) |
| | | | 5900(13,010) | 2150(84.6) | |

Standard mast is shown in broad frame.
 * Load capacity at 600mm (24in.) load center.
 ** 1280mm (50.4 in.) height load backrest.
 *** Free lift and Overall height (Extended) shown are for truck without load backrest.

Performance may vary due to operations. The performance shown represents nominal values under typical operating conditions. Most values shown in this publication are rounded. Therefore, direct conversion between metric and imperial may be slightly different from those shown. Specifications are subject to improvements and changes without notice. If these specifications are critical, please discuss the proposed application with your distributor or dealer.

The illustrations do not necessarily show the standard version and features of the equipment. Features and specifications may vary by country and region. Products and specifications are subject to change without prior notice. Please contact your Komatsu dealer for detail information.

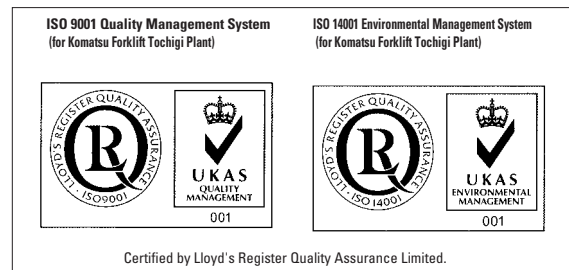

Komatsu Forklift Co., Ltd.

Head office 2-3-4, Akasaka, Minato-ku, Tokyo 107-8474, Japan

<http://www.lift.co.jp>

Fax 81-3-3224-7551 (Tokyo, Japan)